

EAH, EBH Series



**UL Recognized
CSA Certified
VDE Approved**



EAH Series

This is a new generation of compact medical RFI filters with an IEC socket. A new design in internal structure and manufacturing process makes this series cost effective. This health care series supersedes the H series by providing superior differential mode performance while still maintaining a maximum leakage current of 2 micro amps.

EBH Series

Also a compact medical RFI filter with IEC socket, the EBH series is a cost effective alternative to the H series. Electrically the EBH provides enhanced differential mode performance compared to both the EAH and the H series. These filters provide RFI common and differential mode performance while still allowing medical equipment to meet UL leakage current specifications for medical and dental equipment.

Additional information on UL544 specification is listed in Appendix C.

Note: When using the models with an IEC connector, remember that the leakage current of the companion line cord, GA400, is more significant than that of the filter - which may disqualify this line cord from use in patient care applications.

Electrical Schematic

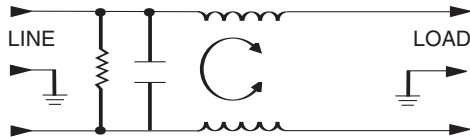

Resistor location for reference only.

Specifications

Maximum leakage current, each line-to-ground	
@ 120 VAC 60 Hz:	2 μ A
@ 250 VAC 50 Hz:	5 μ A
Hipot rating (one minute):	
line-to-ground	1500 VAC
line-to-line	1450 VDC
Operating frequency:	50/60 Hz
Rated voltage (max.):	250 VAC

Minimum insertion loss in dB:

Line-to-ground in 50 ohm circuit

Current Rating	Frequency-MHz								
	.01	.05	.1	.15	.5	1	5	10	30

EAH Models

1A	8	21	29	32	42	45	32	30	19
3A	-	5	10	15	25	27	30	27	22
6A	-	-	5	6	19	21	24	20	15
10A	-	-	1	5	9	12	12	12	12

EBH Models

1A	8	21	29	32	42	45	32	25	19
3A	-	5	10	15	25	27	30	27	22
6A	-	-	5	8	17	20	24	23	18
10A	-	-	-	3	8	12	12	12	12

Line-to-line in 50 ohm circuit

Current Rating	Frequency-MHz				
	1	1.5	5	10	30

EAH Models

1A	5	13	28	32	25
3A	4	6	20	27	28
6A	2	5	19	25	27
10A	1	5	15	22	27

Current Rating	Frequency-MHz					
	.15	.5	1	5	10	30

EBH Models

All Ratings	1	10	18	30	31	31
-------------	---	----	----	----	----	----

EAH, EBH Series

Case Style

EAH1/EBH1

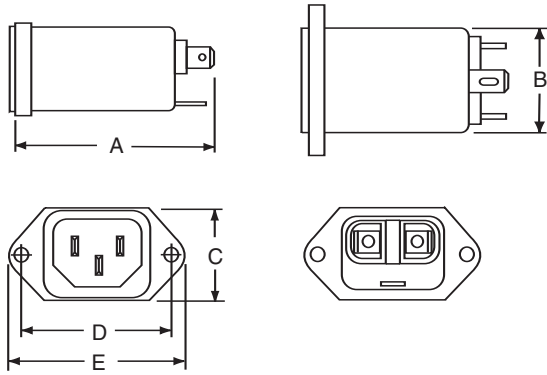

Typical dimensions:

Terminals: .250 [6.35] (5)
Slot: .07 x .16 [1.8 x 4.1]

Holes: .07 [1.8] Dia. (2)
Mounting Holes: .132 [3.35] Dia. (2) with .236 Dia.
x 90° countersunk for #4 Flathead Screw

Case Dimensions

Part No.	A (max)	B (max)	C (max)	D $\pm .010$ $\pm .25$	E (max)
EAH1	2.15 <i>54.61</i>	1.12 <i>28.45</i>	.90 <i>22.86</i>	1.575 <i>40.01</i>	1.98 <i>50.29</i>
EBH1	2.15 <i>54.61</i>	1.12 <i>28.45</i>	.90 <i>22.86</i>	1.575 <i>40.01</i>	1.98 <i>50.29</i>

Part Numbers

1EAH1	1EBH1
3EAH1	3EBH1
6EAH1	6EBH1
10EAH1	10EBH1
Line Cord No.	GA400
Insulating Boot No.	FA601

Recommended Panel Cutouts

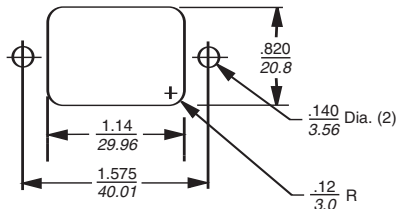

Panel Cutout (Front mount)

Tolerance $\pm .005$ [0.13]

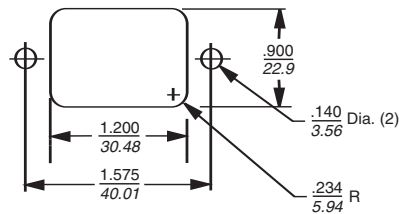

Panel Cutout (Back mount)

Tolerance $\pm .005$ [0.13]